

Anchor - Single Post 2
Part Number 21700-02

Anchor Body

The anchor shall be fabricated from bronze and 300 series stainless steel. The anchor body shall be machined from bronze bar stock and shall be 3 1/2" (8.89cm) O. D. x 2 1/2" (6.35cm) I. D. Two (2) 7/16" (1.11cm) diameter slots shall be machined into the top surface of the anchor to serve as the starting platform-locating index. The bottom plate of the anchor shall be stainless steel and shall be bolted in place. A flat shall be machined on one side of the anchor body providing anti-rotation protection.

Plug

A stainless steel slip cap shall be provided. The welded portion of the cap shall be of the MIG type and applied using type 308-welding rod for corrosion resistance. The cap will fill the anchor opening when the starting platform is not in use. A stainless steel cap removal tool shall be provided.

Bonding

A bonding screw shall be provided. The bonding screw will be 18-8 stainless steel.

Warranty

Two year limited warranty.

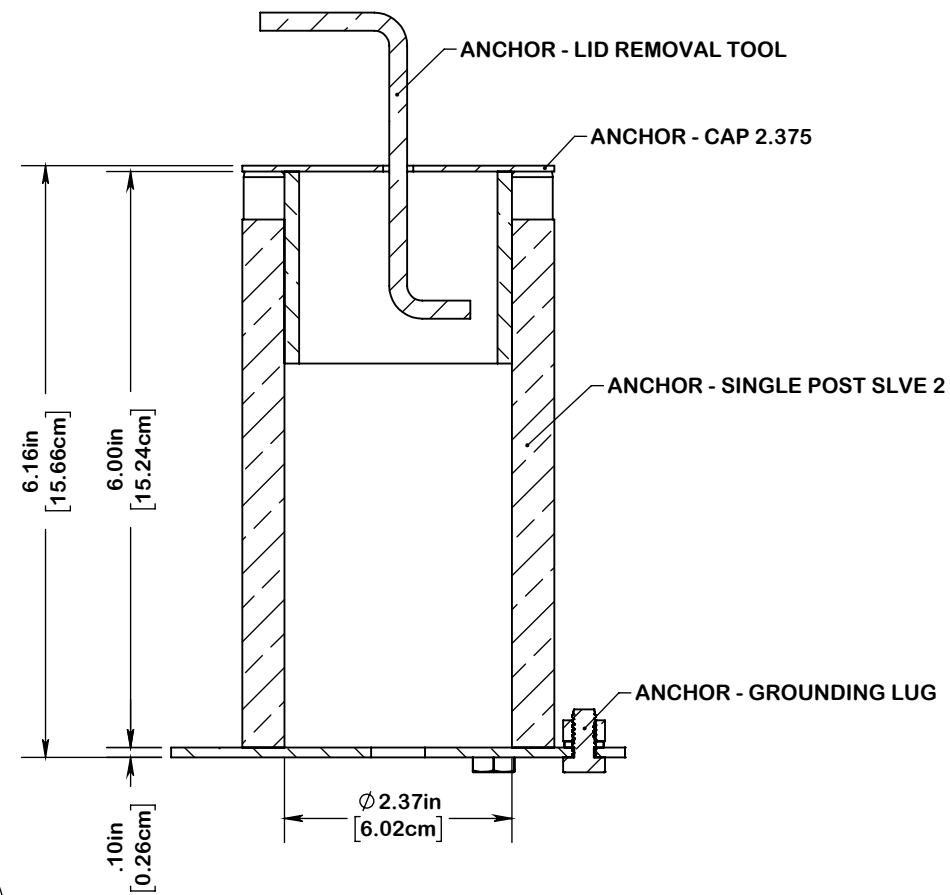

SECTION A-A

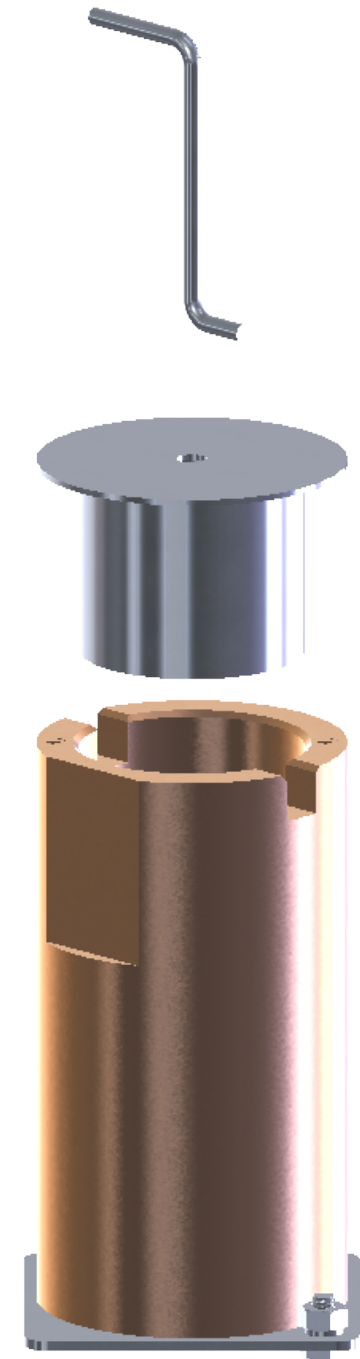
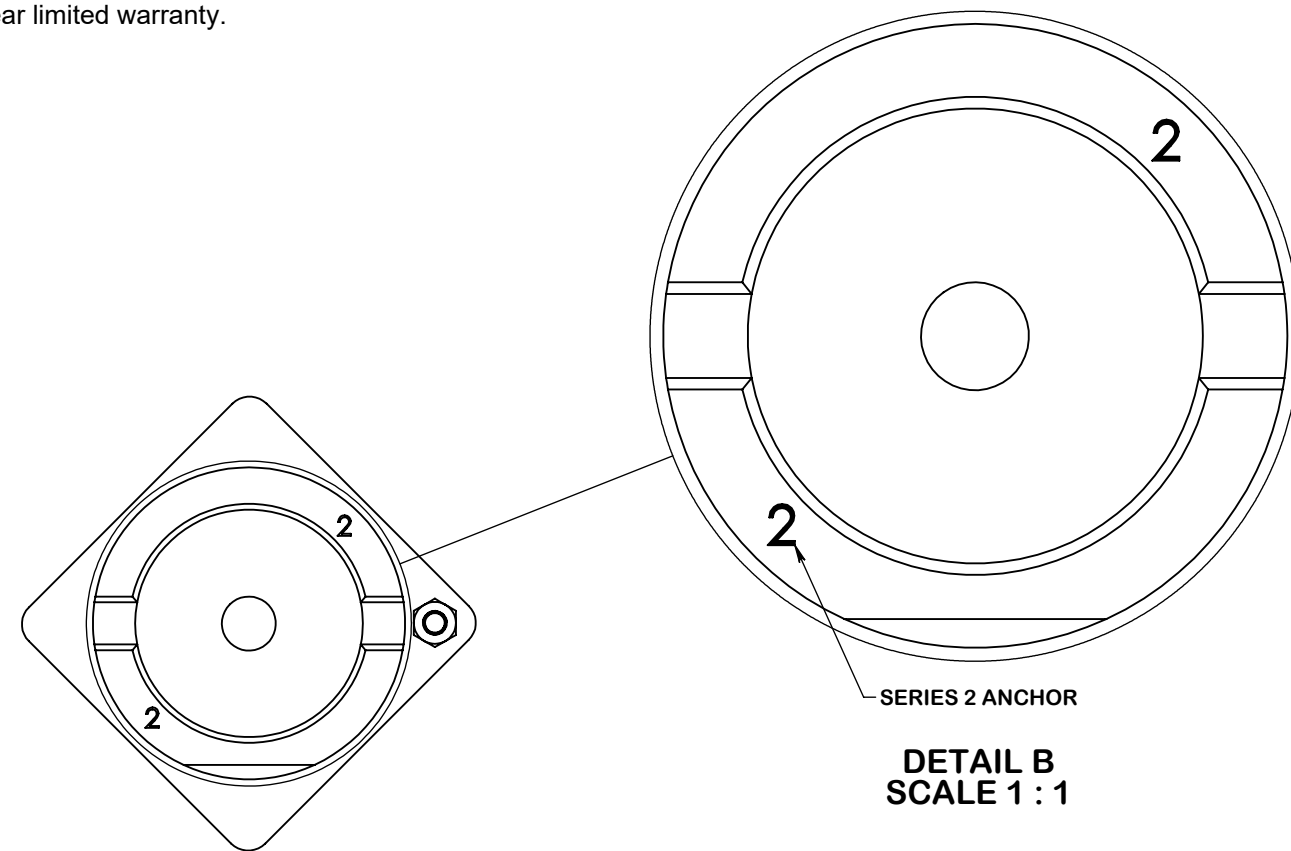

SPECTRUM
Aquatics
 A PLAYCORE Company
 7100 Spectrum Lane Missoula, Montana 59808
 800.791.8056 www.spectrumaquatics.com

ENGINEERING DATA

PRODUCT:	ANCHOR - SP 2 -			
MODEL #:	21700	CATALOG #:	21700	REVISION: A
MATERIAL:	BRONZE - STAINLESS STEEL			
FINISH #:	N/A			

NOTE:

⚠ DIMENSIONS VARY WITH SPECIFIC APPLICATIONS. SPECIFICATIONS ARE NOMINAL AND ARE SUBJECT TO CHANGE. PLEASE CONTACT SPECTRUM AQUATICS FOR CUSTOM APPLICATIONS